



- Threaded versions equipped with flat seat F union connections, therefore, easy installation and/or maintenance;
- Self-cleaning: Dirt separator equipped with discharge cock;
- Hydraulic separator supplied in a kit complete with insulation shell and gas exhaust device.

PRODUCTION RANGE

Code	Size	Max. flow rate (l/h)
617.06.12	1"	2.500
617.07.12	1"1/4	4.000
617.08.12	1"1/2	6.000
617.09.12	2"	8.500
617.09.72	DN50	9.000
617.10.72	DN65	18.000
617.11.72	DN80	28.000
617.13.72	DN100	56.000
617.14.72	DN125	75.000
617.15.72	DN150	110.000

DESCRIPTION

The *Hydraulic separator* is a pre-dimensioned manifold with the task of making the primary and secondary circuits independent if, hydraulically connected, they are equipped with their own circulation pumps.

THE PURPOSE:

The connection of the *Separator*, as hydraulic separation element between two circuits, primarily ensures the following functions;

- **cancel the mutual influence between the pumping stations of the different circuits;**
- **promotes the sedimentation, the collection and unloading of micro-impurities suspended in the fluid;**
- **promotes the deaeration of the circuits** by means of the automatic removal of the dissolved gases.

THE PRODUCT:

The RBM *Hydraulic separators* are supplied complete with the following accessories pre-assembled:

- Megaluft model deaerator;
- ball valve for bottom discharge and mud drainage;
- thermal insulation shell.

To facilitate the assembly of auxiliary components, such as temperature and pressure control components, system filling circuit, safety pipe for connection to expansion tank, all RBM *Hydraulic separators* are supplied with threaded sleeves.

THE CHOICE: The *Hydraulic separator* is chosen on the basis of the maximum recommended flow rate for the connection nozzles. Below is a table indicating the maximum flow rate value for each size.

Size	Max. flow rate (l/h)
1"	2.500
1"1/4	4.000
1"1/2	6.000
2"	8.500
DN50	9.000
DN65	18.000
DN80	28.000
DN100	56.000
DN125	75.000
DN150	110.000

WARNINGS: Particular attention must be paid, in the design phase, to the possible temperature variations that the circuits may suffer due to the mix induced inside the *Hydraulic separator*. A secondary circuit with flow rate higher than that circulating in the primary circuit (fig. 2), generates, in fact, through the *Hydraulic separator*, a flow temperature below that of the primary circuit.

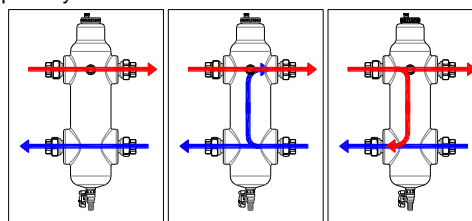
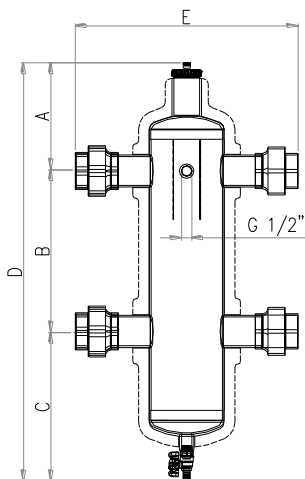

Fig.1

Fig.2

Fig.3

DIMENSIONAL FEATURES



Threaded hydraulic separator						
Code	Size	A mm	B mm	C mm	D mm	E mm
617.06.12	G 1"	160	220	186	566	259
617.07.12	G 1"1/4	171	240	211	622	248
617.08.12	G 1"1/2	226	260	221	707	331
617.09.12	G 2"	202	300	280	782	414

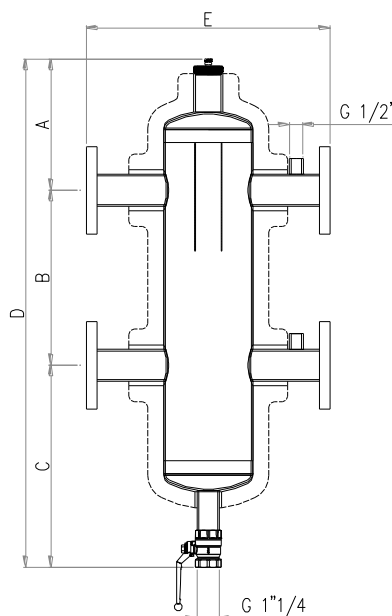

Flanged hydraulic separator						
Code	Size	A mm	B mm	C mm	D mm	E mm
617.09.72	DN50	247	330	381	958	460
617.10.72	DN65	247	330	381	958	460
617.11.72	DN80	469	450	464	1383	526
617.13.72	DN100	469	450	464	1383	529
617.14.72	DN125	339	560	394	1293	670
617.15.72	DN150	339	560	394	1293	670

CONSTRUCTION FEATURES

Separator Body	: painted steel with epoxy powders
Ball valve body	: nickel-plated
Deaerator body	: brass
Ball valve seals	: PTFE
Deaerator seals	: EPDM PEROX and NBR
Threaded connections	: unions F UNI-EN-ISO 228
Flanged connections	: PN16

TECHNICAL FEATURES

Max. operating pressure:		
- separator body	: 10 Bar	(1000 kPa)
- ball valve	: 25 Bar	(2500 kPa)
- Megaluft deaerator	: 10 Bar	(1000 kPa)

Allowed temperatures		
- body and deaerator	: 0 ÷ +115 °C	
- ball valve	: -15 ÷ +120 °C	

OPERATING PRINCIPLE

When there are thermal fluid production circuits, more or less complex, equipped with their own circulation pumps and secondary distribution circuits to the utility, also equipped with more dedicated pumps, it is possible to see continuous variations of the flow rates on the primary circuit (boiler or cooling units cascade), and on the secondary circuit (climatic compensation of the temperature, thermal closing zones with two-way valves, etc...).

The continuous variations of flow rate, which normally occur in the majority of distribution circuits deriving directly from a thermal fluid production system, may be due to:

- alteration of the circuits' balancing;
- variation of the flow rate and static pressure performance provided by the pumps, with the consequent variation of the mutual influence that a pumping station can have on the other (flow rate increase or reduction), and alteration of the already precarious balance between the primary and secondary circuits. In fact, the pumping station of the primary circuit is positioned in series to the pumping station of the secondary circuit.
- the consequent performance variation of the systems and of the terminal equipment with respect to the design conditions.

The connection of the hydraulic separator, as a component of hydraulic separation between the two circuits, cancels the influence and interference between the different pumps present on the various circuits, working a sort of virtual division between the primary circuit and the secondary one.

This is possible thanks to the reset of the pressures induced by the pumping stations due to the sudden expansion of the fluid inside the *Hydraulic separator*.

The flow of a circuit can migrate, only by inertia, to the suction nozzle of the other circuit, or short circuit, towards its own suction nozzle, in the case of partial or total reduction of the flow rate of one of the two circuits. This free migration occurs without altering the operating conditions of the two circuits, thanks to the limited drop in pressure that the flows encounter in covering the *Hydraulic separator*.

In the meantime, the fluid, while passing inside the separator is forced to pass through a perforated grid, this has the function of **promoting the sedimentation, the collection and unloading of micro-impurities suspended in the fluid as well as favour the deaeration of the circuits**. The air bubbles rise upwards and are expelled by the air vent device (Megaluft), while the impurities, not having any type of obstacle, descend in the accumulation zone, (so dirt particles do not risk being carried away by the flow running towards the dirt separator outlet), until they are ejected via the opening of the discharge cock.

To the side is a typical layout of the connection of a *Hydraulic separator* as separator between the primary circuit and the secondary circuit.

The *hydraulic separator* is certainly the most suitable place for the connection of an expansion vessel and for the connection of the loading and refill unit.

In the representation the *Hydraulic separator*, also due to the low value of ΔP generated when the fluid passes, **represents the neutral point of the system**. At this point, in fact, the pressure value is always equal to the pre-load pressure of the system (hydrostatic load), with or without pumps running.

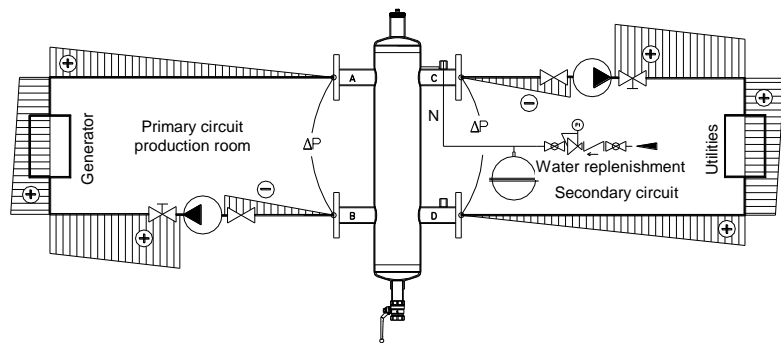
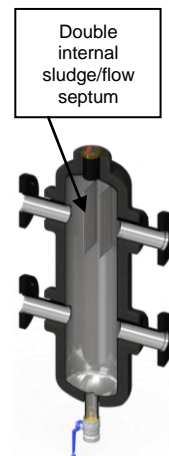

INSTALLATION GUIDE

It is advisable to respect the following basic requirements when installing the *Hydraulic separator*:

- The *Hydraulic separator* must be installed in a **vertical position**, in order to allow optimal operation of the impurity discharge/storage and air vent device.
- With reference to the above diagram, **install the circulators so that both are preferably opposite** in operation with respect to the position of the *Hydraulic separator*.
- **Provide upstream and downstream, suitable interceptions** to allow disconnection of one or both circuits.
- Periodically **drain the sludge settled** at the bottom of the *Hydraulic separator*.

TYPICAL APPLICATIONS

Layout 1:

Application of the *Hydraulic separator* as a separator between the upright column and the independent thermal zones power supplies.

This solution allows the secondary circuit, powering the upright column, not to be hydraulically affected by the operation of the thermal zones.

The head of the secondary circuit will only ensure the circulation of the thermal fluid up to the individual *Hydraulic separators*.

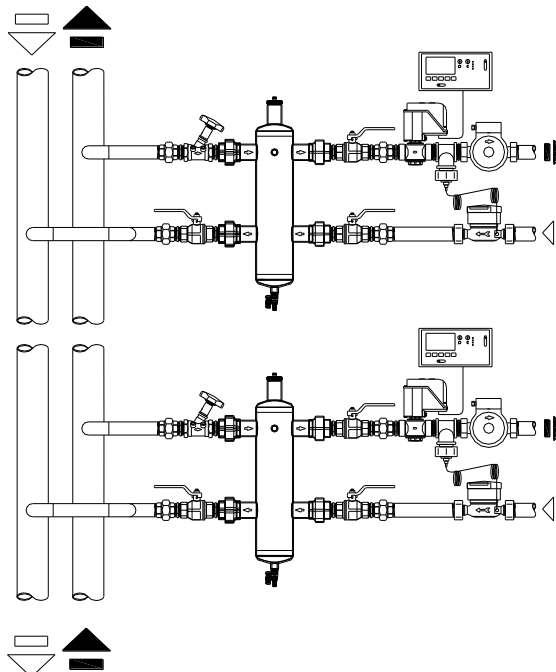

Layout 2:

Application of the hydraulic separator as separator between the primary central circuit and the secondary distribution circuit.

With units supplied by their own pumps (e.g. for circuits with high pressure drops), the *Hydraulic separator* is used as separator with the secondary circuit.

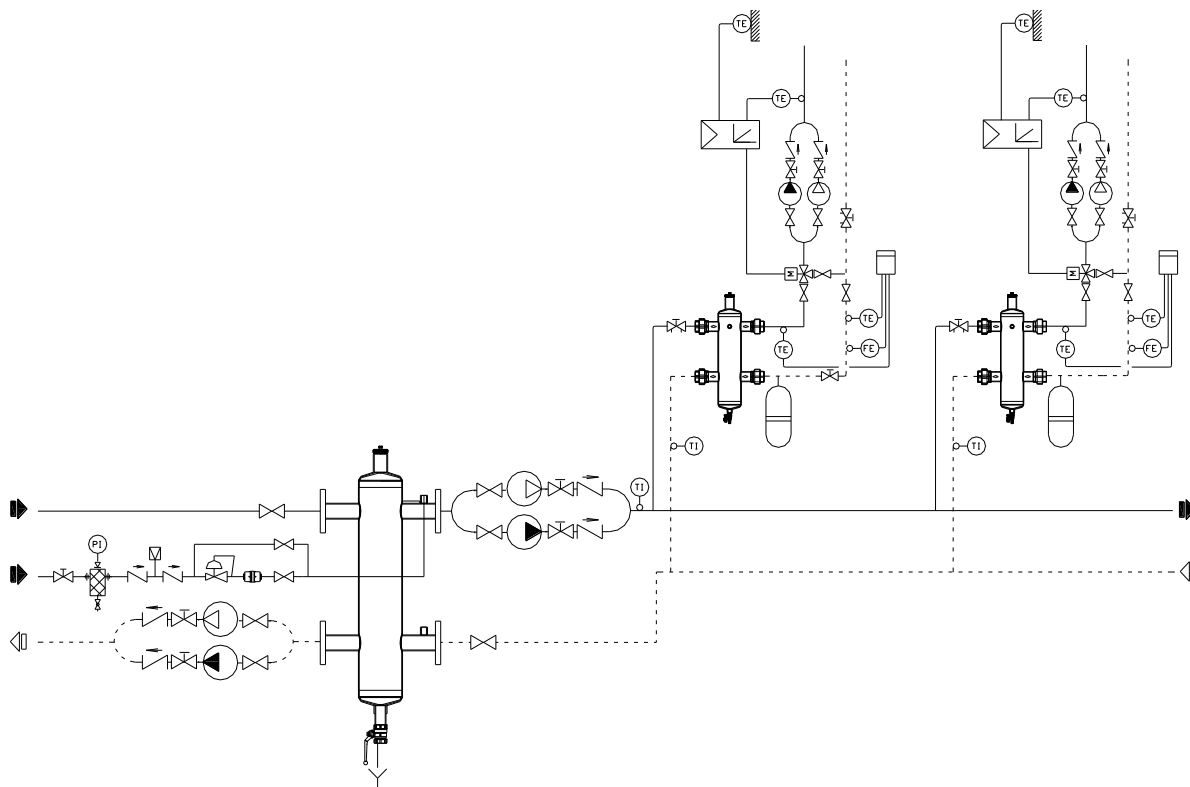

Layout 3:

Application of the *Hydraulic separator* as a separator between the heat production circuit and the distribution circuit to the utility.

Typical solution to be used for two-pipe systems for the air conditioning of offices or commercial activities.

This solution allows the hot primary circuit to be hydraulically independent of the serviced utilities (the cold primary circuit is made independent from the inertial tank).

The head of the secondary circuit pumps guarantees exclusively the circulation of the thermal fluid for the correct supply of the heating equipment.

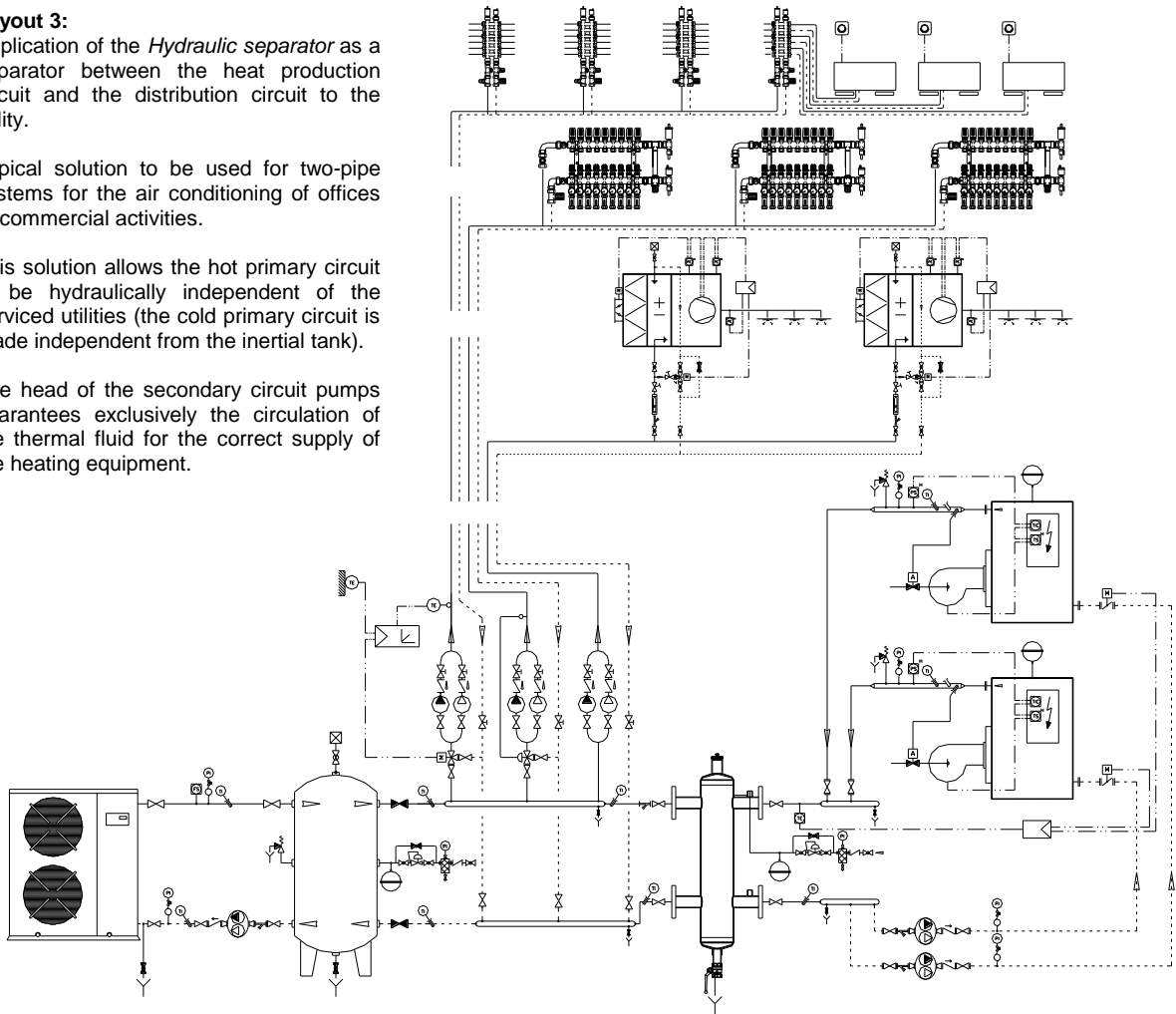

Layout 4:

Application of the *Hydraulic separator* as a separator between a wall boiler and the supply system of a residential home equipped with two heating zones.

Typical solution to be used when the boiler circulator performances are not sufficient to guarantee the correct supply of the heating equipment.

This solution makes it possible to:

- avoid any tampering with the boiler, in order to replace the circulator, with consequent loss of warranty;
- prevent the insertion of a second circulator ensuring the correct supply of the heating elements, but would abnormally and dangerously increase circulation inside the boiler beyond the values admitted by the manufacturer;
- supply for heating elements with flow rates or ΔT different to the work temperatures of the boiler.

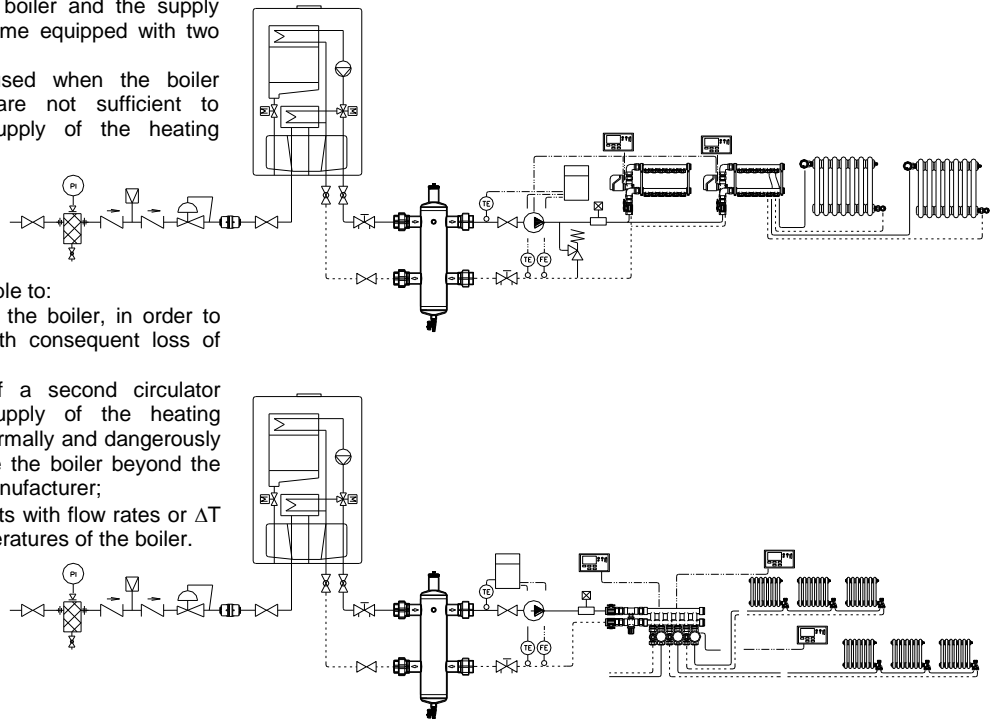

SPECIFICATION ITEMS

SERIES 617 (threaded)

Pre-dimensioned, threaded hydraulic separator with the task of making the primary and secondary circuits independent if equipped with own circulation pumps.

Separator body in painted steel with epoxy powders. Valves body and brass deaerator. Ball valve seals in PTFE. Deaerator seals in EPDM PEROX and NBR.

union threaded connections F UNI-EN-ISO 228. Available sizes 1" ÷ 2". Front connection for threaded accessories 1/2" UNI-EN-ISO 228.

Max operating pressure separator body 10 Bar. Max. operating pressure ball valve 25 Bar. Deaerator max. operating pressure 10 Bar
Deaerator allowed temperatures 0 ÷ +115°C. Ball valves allowed temperatures -15 ÷ +120 °C

SERIES 617 (flanged)

Pre-dimensioned, flanged hydraulic separator with the task of making the primary and secondary circuits independent if equipped with own circulation pumps.

Separator body in painted steel with epoxy powders. Valves body and brass deaerator. Ball valve seals in PTFE. Deaerator seals in EPDM PEROX and NBR.

PN16 flanged connections. Available sizes DN50 ÷ DN150. Front connection for threaded accessories 1/2" UNI-EN-ISO 228.

Max operating pressure separator body 10 Bar. Max. operating pressure ball valve 25 Bar. Deaerator max. operating pressure 10 Bar
Deaerator allowed temperatures 0 ÷ +115 °C. Ball valves allowed temperatures -15 ÷ +120 °C



RBM spa reserves the right to improve and change the described products and related technical data at any moment and without prior notice: always refer to the instructions attached with the supplied components; this sheet is an aid, should the instructions be extremely schematic.
Our technical department is always at your disposal for any doubt, problem or clarification.

RBM Spa
Via S. Giuseppe, 1
25075 Nave (Brescia) Italy
Tel. 030-2537211 Fax 030-2531798
E-mail: info@rbm.eu - www.rbm.eu